

Calculation of the Spiral Case – 057 CALDsoft7.

1- To insert the sectors, the user just needs to click in 'new sector' and must know that each line of the entry screen corresponds to a profile, in other words, if he desires three sectors, four profiles will be necessary. See the example below:

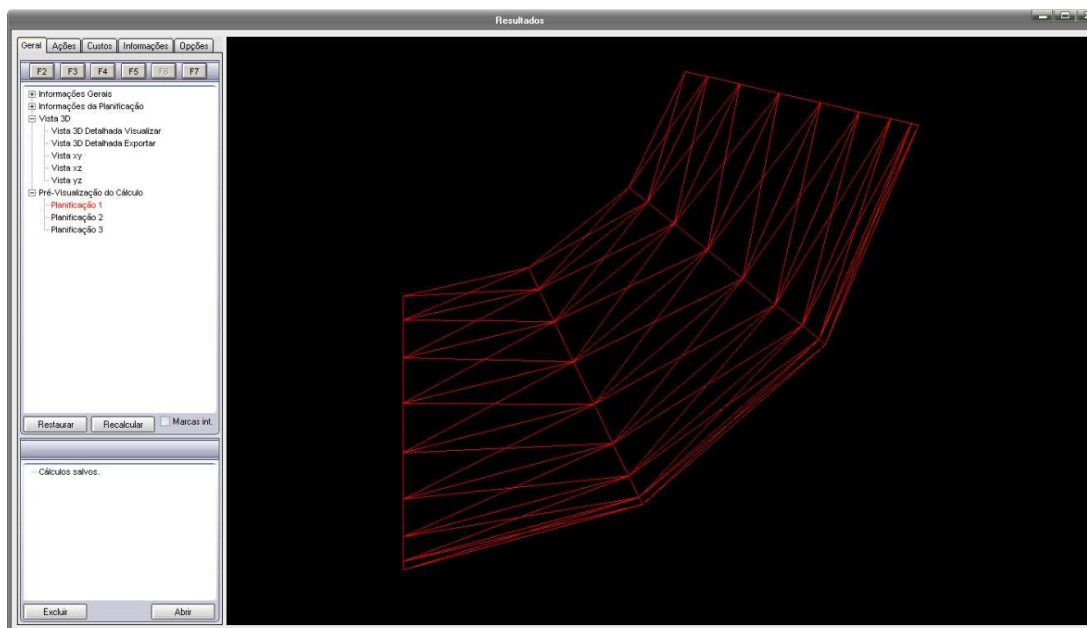
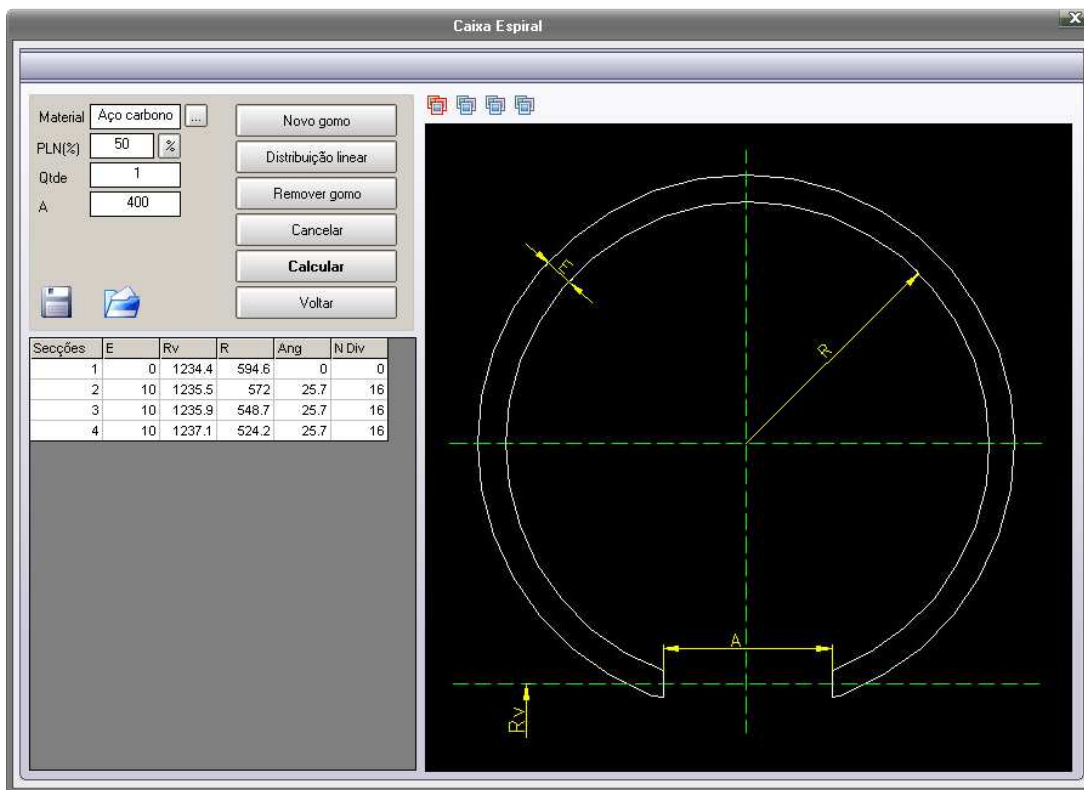

2- To remove a profile, just click in 'remove sector' and then the last line or profile will be eliminated.

3- The selection of the material may be done before of the execution of the calculus, in the field at the superior left side superior of the entry screen.

4- To insert the width of the material the user must double click on the field of the width. After that the field will be selected, then just click on the field where you find the value of the width you want to alter and a screen where the width may be selected will open.

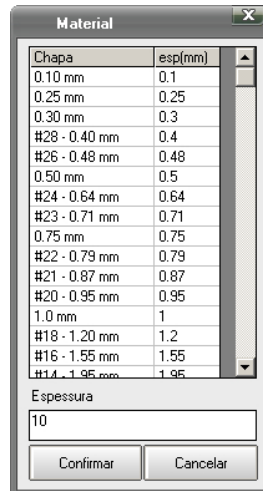

5- The variable NLP refer to the neutral line of the part, in other words, a line where the tensions of the conformation nullify. In small widths (smaller than 30 mm), for example, the NLP may always be 50%.

6- The variable Qty refers to the quantity of parts, which means, if you wish a spiral case or a 'snail' the quantity will be 1.

7- The variable A refers to the aperture of the sectors of spiral case, as can be observed in the first image of the entry of data.

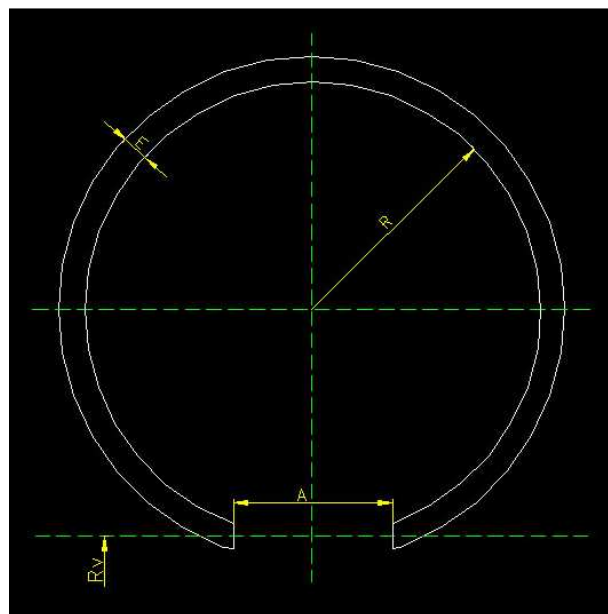

8- The variable R refers to the measure of the Internal Ray of each sector.

9- The variable Rv refers to the measure of the ray of curvature of the Case. This measure goes up to half of the width of the sector, as can be seen in the previous figure (item 7).

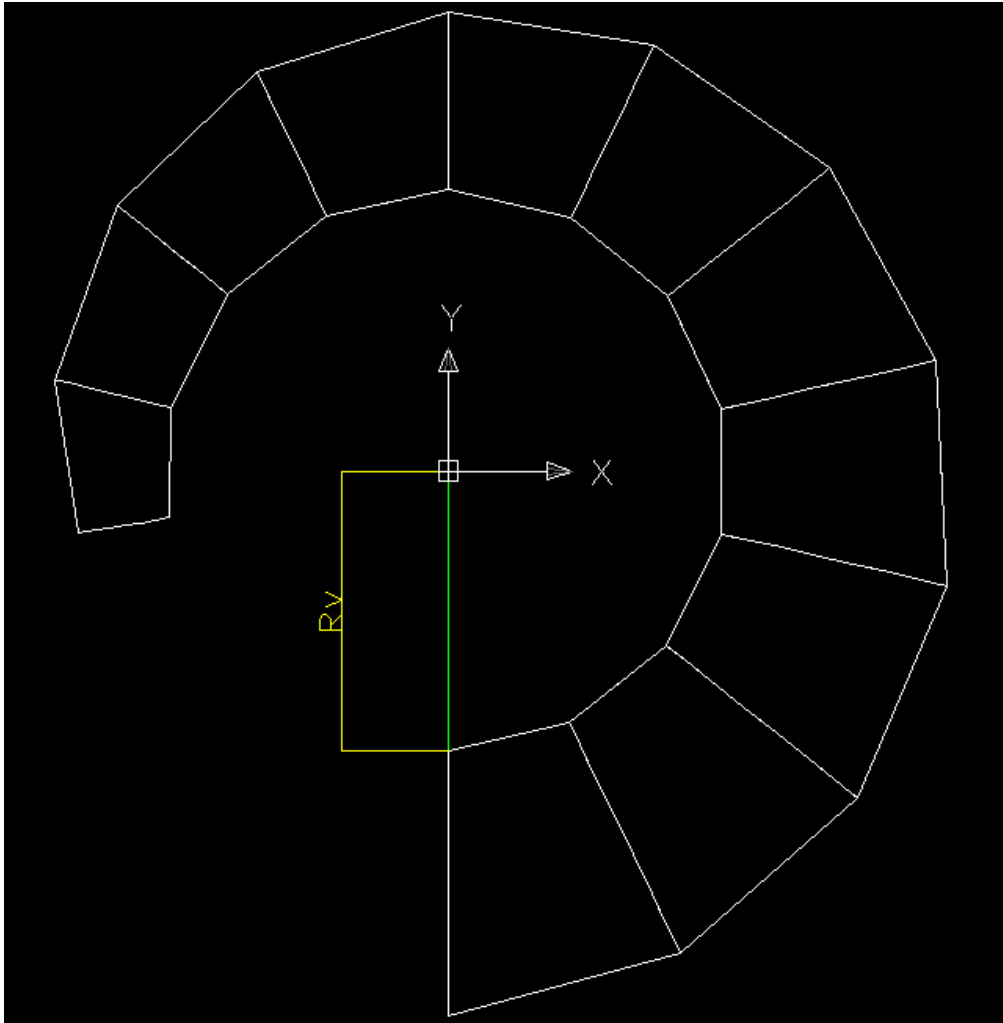

10- The variable Ang will determinate the angle of each one of the profiles from the first and determinate sector by sector. For example:

If the user desires a spiral case of 360° and wants to obtain 12 sectors (equivalent to 13 profiles), in the first profile the angle must be 0° . Then the user divides the final angle by the number of sectors desired and obtains a value equal to 30 , in other words, 30° in each one of the profiles.

11- Linear Distribution – There are four fields where the user may use this option: Rv, R, Ang, N div. To fulfill the chart, for example, with the values of Rv (Variable Ray) the user may insert the values of each one of the profiles if he/she poses the project in CAD, or may only insert the value in the first profile/line and the value of the last profile/line. The other lines will be automatically fulfilled by the software:

Material: Aço carbono ...

PLN(%): 50 %

Qtde: 1

A: 400

Novo gomo

Distribuição linear

Remover gomo

Cancelar

Calcular

Voltar

Secções	E	Rv	R	Ang	N Div
1	0	1200	594.6	0	0
2	10	0	565.6	30	16
3	10	0	536.6	30	16
4	10	0	507.6	30	16
5	10	0	478.6	30	16
6	10	0	449.6	30	16
7	10	0	420.6	30	16
8	10	0	391.7	30	16
9	10	0	362.7	30	16
10	10	0	333.7	30	16
11	10	0	304.7	30	16
12	10	0	275.7	30	16
13	10	1250.3	246.7	30	16

Material: Aço carbono ...

PLN(%): 50 %

Qtde: 1

A: 400

Novo gomo

Distribuição linear

Remover gomo

Cancelar

Calcular

Voltar

Secções	E	Rv	R	Ang	N Div
1	0	1200	594.6	0	0
2	10	1204.2	565.6	30	16
3	10	1208.4	536.6	30	16
4	10	1212.6	507.6	30	16
5	10	1216.8	478.6	30	16
6	10	1221	449.6	30	16
7	10	1225.2	420.6	30	16
8	10	1229.3	391.7	30	16
9	10	1233.5	362.7	30	16
10	10	1237.7	333.7	30	16
11	10	1241.9	304.7	30	16
12	10	1246.1	275.7	30	16
13	10	1250.3	246.7	30	16

12- To insert the data in one of the four fields of the chart (Rv, R, Ang, N div) just double click and observe if the field is selected. To erase the values, use the key 'Backspace'.

Caldsoft Comercial de Sistemas de Informática Ltda.
 Rua João Marcatto, 13 – sala 202/203 – Centro
 89251-670 – Jaraguá do Sul – SC – www.caldsoft.com.br